

# Processing & Utilities

- Processing Utilities Library
- Noise Analysis
- Thermal Analysis
- Sensitivity Analysis
- Monte Carlo Analysis
- Potentiometer Analysis
- Minimum Phase Transform
- Delay Phase Transform
- Binary Math Operations
- Unary Math Operations

**Sensitivity Analysis**

Circuit Name: Custom Components: 26 Output Node: Data Curve 2 Lowpass

Worst Case Sensitivity Data

Index	Comp Name	Comp Value	Frequency (Hz)	Sensitivity
1	R1	1.0200k	1.0116k	2.7479
2	C1	270.0000n	840.6853	1.0024
3	R2	1.2700k	1.0116k	6.0300
4	R3	1.2700k	1.0353k	5.2438
5	R4	1.2100k	1.0596k	3.2984
6	R5	649.0000	10.0000k	997.6865m

Buttons: Run Analysis, Save as Text File, Ok, Cancel, Help

**Utilities Library Scale View**

- Import Curve Data
- Export Curve Data
- Export Graphics
- Export Target Data
- Copy Graphics to Clipboard
- Copy Target Data to Clipboard
- Copy Component Data to Clipboard
- Curve Editor
- Curve Capture

**Export Graph**

Graph to Export: Magnitude Response

Type of Image: Vector

Image Pixel: 64

File Path: D:\WINNT\Profiles\Administrator\Desktop\MR\_MAG

Buttons: Ok, Cancel, Help

**Noise Density**

**Noise Analysis**

Parameters: Data Curve: 2 Lowpass

Weight: Flat, ANSI-B, ANSI-A, ANSI-C

Total Noise: Bandwidth (Hz): 9.9000k, Noise (V): 2.8025u, Noise (dBm): -108.835

Lo Frequency Limit: 100.0000, Noise (V/RTHz): 18.1944n, Noise (dBm/RTHz): -152.587

Hi Frequency Limit: 10.0000k, Noise (V/RTHz): 2.9405n, Noise (dBm/RTHz): -168.418

Buttons: Ok, Cancel, Help

**Export Curve Data**

Domain: Frequency, Time

Frequency Domain Data: Magnitude (dB), Phase (Deg), Delay (Sec), Amplitude (Volts), Real (Volts), Imag (Volts)

Time Domain Data: Impulse (Volts), Step (Volts)

Curve: Data, Guide: 32

File Path: C:\Program Files\F

Buttons: Ok

**Magnitude Response**

**Import Curve Data**

Data to Import: Time Domain: Impulse (Volts), Freq Domain: Mag(dB), Phase (Deg), Real (Volts), Imag (Volts)

File Name Path: C:\Program Files\Filtershop\Projects\Brochure\S11.dat

Guide Curve: 32

Buttons: Ok, Cancel, Help

**Magnitude Response**

**Thermal Analysis**

Parameters: Data Curve: 2 Lowpass, Rel Temp (C): 25.00

Lo Temp (C): -25.00, Hi Temp (C): 75.00, Steps: 11

Component Temp Coef Enable: Resistors, Potentiometers, Capacitors, Inductors, FDNRs

Buttons: Ok, Cancel, Help

**Curve Capture**

Graphics Image: Magnitude > Sound Pressure

Guide Curve: 1: Curve Capture

Color Matching: Exact Color, ±1% Color, ±5% Color, ±10% Color

Vertical Axis: Magnitude (dB), Phase (Deg), Delay (Sec), Noise (V/RTHz)

Scan Direction: Top to Bottom, Bottom to Top

Horizontal Axis: Log Frequency, Linear Frequency

Reference Point Data, Upper Right: X Pixel: 999, Y Pixel: 26, Frequency (Hz): 40.0000k, Magnitude (dB): 100.0000

Reference Point Data, Lower Left: X Pixel: 80, Y Pixel: 122, Frequency (Hz): 10.0000, Magnitude (dB): 20.0000

File Path: D:\Program Files\Projects\Ishop\Projects\Brochure\Sp1plot.bmp

Buttons: Load File, Lower Left, Upper Right, Color, Curve Color, Ok, Cancel, Help

**Magnitude Response**

**Monte Carlo Analysis**

Parameters: Data Curve: 2 Lowpass, Runs: 30

Components: Resistor, Capacitor, Inductor, FDNr, Potentiometer

Any Value Tolerance: Resistor (±%): 1.0000, Capacitor (±%): 1.0000, Inductor (±%): 0.1000, FDNr (±%): 0.1000, Pot (±%): 0.1000

Buttons: Ok, Cancel, Help

**Curve Editor**

Magnitude Delay Lo Limit Frequency (Hz) Hi Limit Frequency (Hz) Value at Top Value per Div Units

Phase Noise 0.0000 5.000 dB

**Magnitude Response**

Buttons: Show Data Curves, Show Guide Curves, Guide Curve: 31: Curve Editor, Read, Write, Ok, Cancel, Help

**Magnitude Response**

**Potentiometer Analysis**

Parameters: Data Curve: 2 Output, Steps: 11

Components:

Index	Enable	Name	Value	Taper
1	<input checked="" type="checkbox"/>	P1	10.0000k	AR-B
2	<input type="checkbox"/>	P2	20.0000k	AR-E
3	<input type="checkbox"/>	P3	20.0000k	AR-E
4	<input type="checkbox"/>	P4	20.0000k	AR-E
5	<input type="checkbox"/>	P5	20.0000k	AR-E

Buttons: Ok, Cancel, Help

# Design Examples I

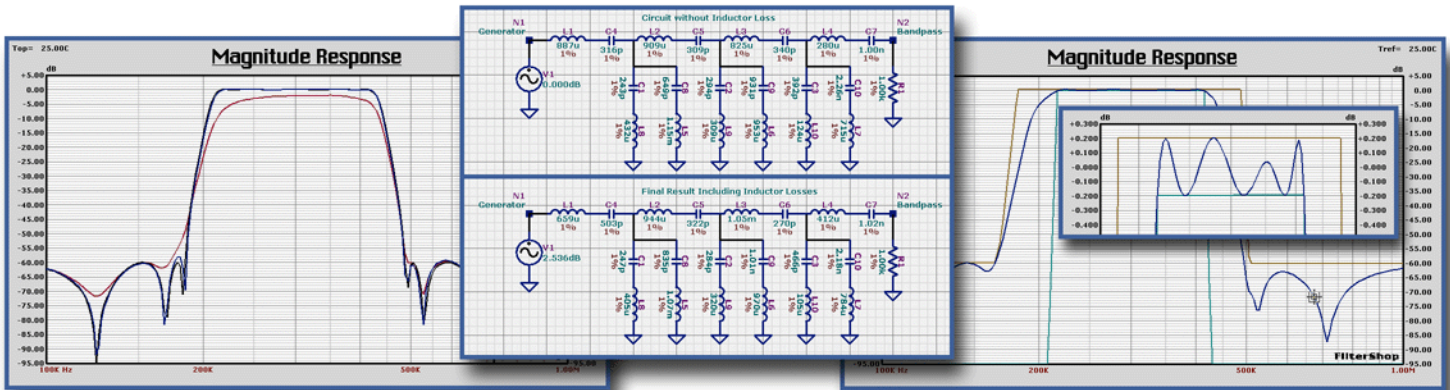

## 7th Order Passive Elliptic Bandpass Filter with Inductor Loss Optimization

This example demonstrates the ability to optimize passive networks to correct for component losses. A 300kHz Elliptic Bandpass filter with ripple of 0.2dB and attenuation of 60dB. The Black curve shown in the left graph represents the ideal Bandpass target response. The Blue curve (almost on top of the Black) is the resulting circuit synthesis using 1% components with no losses for the inductors. The Red curve is the same circuit when the inductor losses are included. The right graph shows the constraints used for the optimization in Gold and Green, and the final circuit response including inductor losses in Blue. The circuit schematic component values with and without inductor loss are shown in the center.

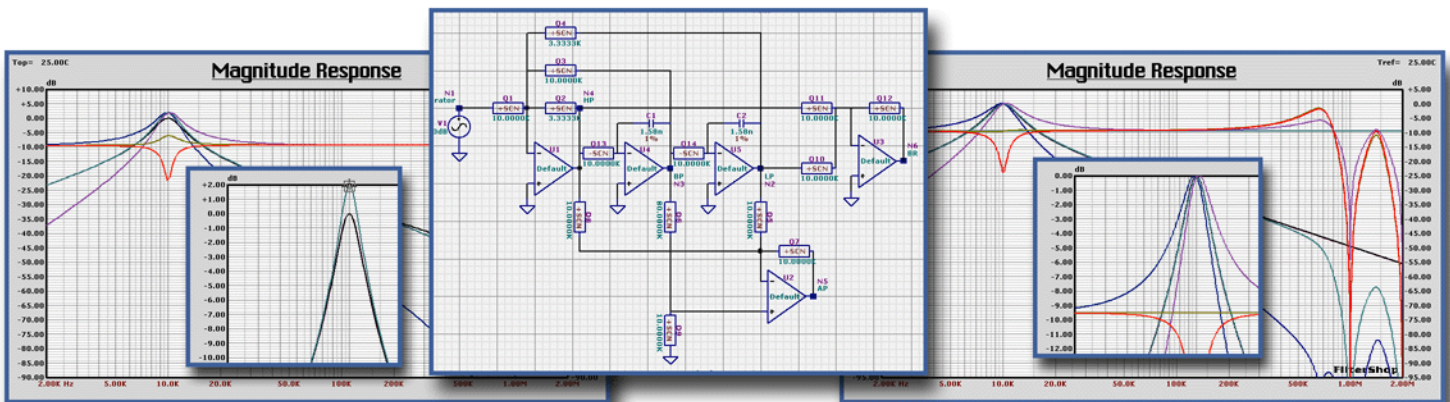

## Switched Capacitor State Variable Filter with Correction Optimization

In FilterShop™, switched capacitor components can be optimized as easy as ordinary resistors. This is an attractive feature for SC circuits where  $F_o$  and  $Q$  distortion often occur due to the sampling technology. In this example a 2nd order state variable filter is optimized with a Bandpass target  $F_o$  of 10kHz, a  $Q$  of 3, and a clock of 1MHz. The Black curve in the left graph shows the ideal target, and the Green curve shows the initial synthesis Bandpass circuit response. As shown in the expanded view, the circuit has a  $Q$  and amplitude different than the target. The right graph shows the circuit performance after optimization. The response of the circuit now matches that of the ideal Bandpass target. In addition, all of the other outputs now have their proper response as well. The circuit schematic is shown above in the center.

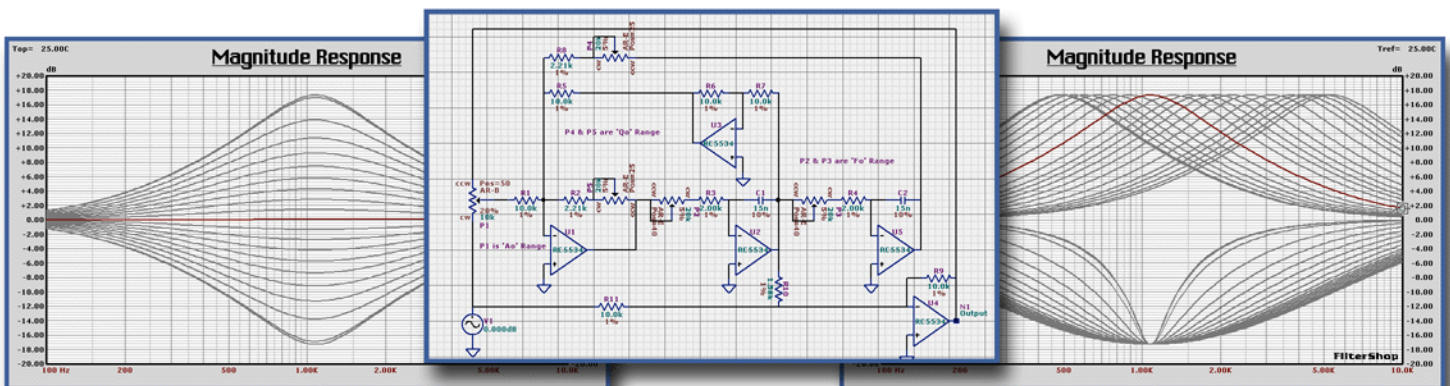

## Audio Parametric Equalizer Design

Equalizers need pots, and pots need special tapers. If you have ever struggled with the two-resistor approach to construct pots in a circuit design, the powerful potentiometer component provided in FilterShop™ is an equalizer designer's dream. With this component you can easily and quickly model circuits including the proper selection of a pot taper. FilterShop™ includes almost 200 standard pot tapers in a library system. The user can also define his own tapers, as well as support for up to 3 taps at any location. The pots used in any circuit can be automatically rotated by any number of steps, even ganged, to produce a family of response curves.

The example shown above illustrates a Bandpass EQ utilizing a 2nd order state variable filter. Synthesis was used to design the state variable filter, and then the filter was placed into an equalizer topology. The left graph shows a sweep of the Gain (Boost/Cut) control pot with 21 steps. The right graph shows two sets of sweeps. The top set shows the ganged rotation of the dual Frequency controls while at maximum boost, and the lower set shows the rotation of the  $Q$  control at maximum cut. By selecting different tapers for the controls, the sweep density can be easily observed and the proper taper selected. This prevents crowding and/or dead-zones in the rotation sweep, either at one end of the control or at the center. The equalizer schematic is shown above.

# Design Examples II

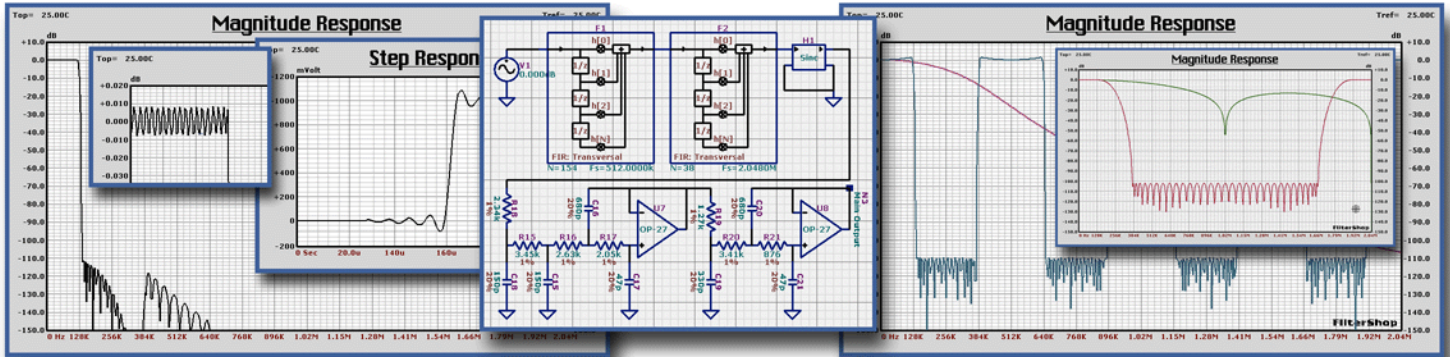

## Digital Multirate Interpolator with 7th Order Analog Bessel Filter

This design features an 8x interpolator with input/output sampling frequencies of 256kHz/2.048MHz, and a 7th order analog Lowpass reconstruction filter. The passband is 0Hz-120kHz  $\pm 0.01$ dB, stopband of 100dB, and flat group delay across the entire passband. The Bessel filter uses a 350kHz corner and reaches 100dB attenuation at the high frequency image edge. The 2-stage FIR was initially optimized using the Multirate dialog, and then the second stage passband was redesigned to include correction for the  $\sin^2/x$  sampling loss, the Bessel response, and the ripple of the first FIR stage as well. The circuit shown above includes an optimized two section unity gain Sallen-Key Lowpass implementation of a modified Bessel filter, a transfer function component to model the sinc response, and the two FIR stages. The special 4th order stage is applied first to provide a pure 2nd order RC Lowpass to ground. This prevents slewing distortion by removing the high frequency edges prior to entering the opamps.

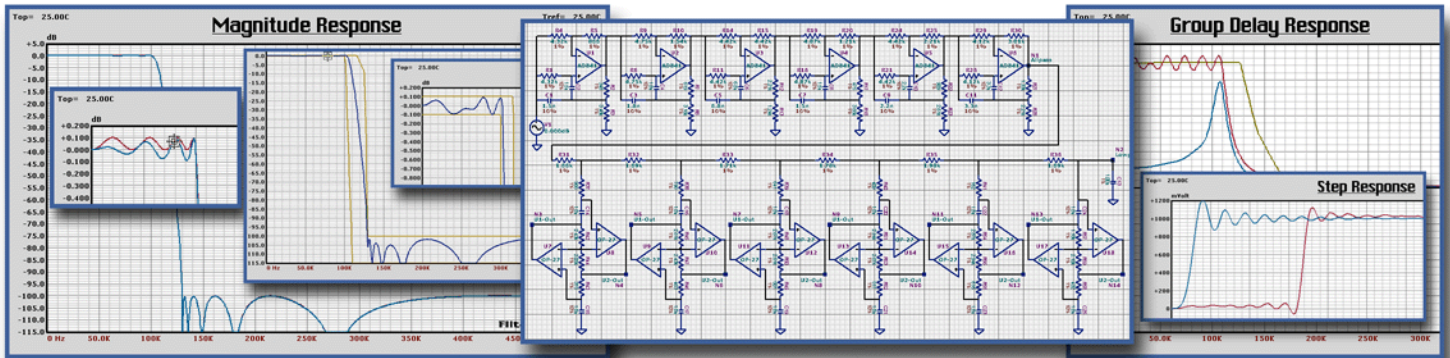

## 12th Order Elliptic Lowpass with Linear Phase Optimization

In this example a 12th order Elliptic Lowpass using an RDC-ladder topology is constructed, with an optimized 12th order Allpass array. The target function is a 3-Pole MCP with 0.1dB ripple, a stopband of 100dB, and a transition width of 30%. The passband edge frequency is 100kHz. The RDC ladder is first designed using synthesis to obtain the initial R,C and D values for the ladder. Next, the six gyrator stages are designed to produce the required D values. A group delay objective curve is created as a flat line about 10% higher than the normal elliptic peak, as shown in the Gold curve of the right graph. A 12th order Allpass target is then optimized for group delay to produce a linear phase result for the filter, as shown by the Red curve in the right graph. The final combination of the Allpass section and ladder is optimized via constraints to produce the required passband ripple and stopband attenuation, as shown in the left graph. The complete circuit is shown above.

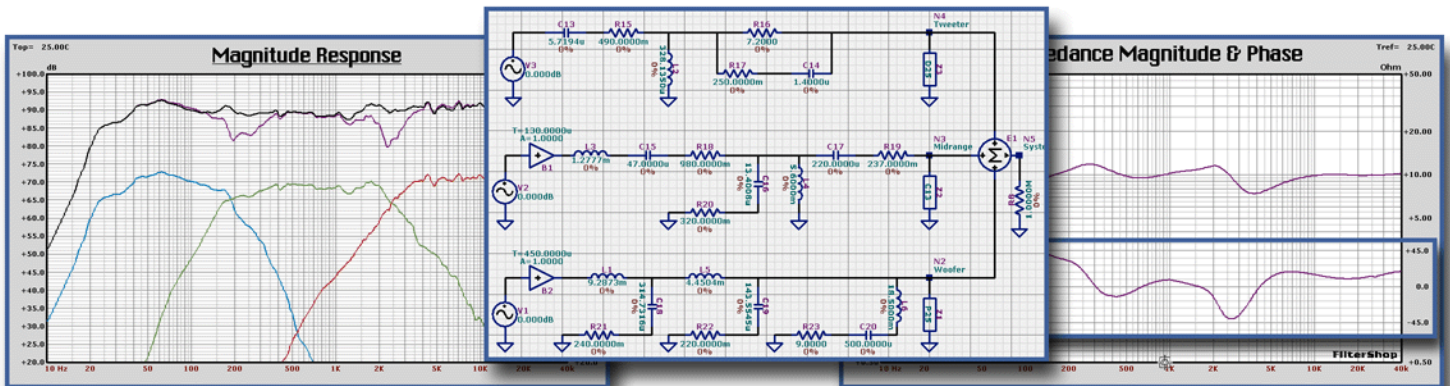

## 3-Way Optimized Passive Audio Crossover with Imported Transducer SPL and Impedance

Precision audio crossovers can be easily designed, both for analog passive/active or digital. In this example the measured SPL-response for each of the three transducers in the prototype enclosure were imported into the program, and loaded into the three Voltage Generators. Likewise, the complex Impedance curves for each transducer were imported and loaded into the three Z components, representing the actual network loads. Two Buffer components ( $T=130\mu\text{s}$  &  $T=450\mu\text{s}$ ) were added after the woofer and midrange generators, to model the true time locations of the transducers. A Summer component is used at the three outputs to sum the complex signals into the system response. The networks for all three sections were then designed and optimized to 4th order Butterworth-6 targets, and then the final combined response again optimized for smoother crossover regions. All of the Inductors include losses for parasitic resistance and capacitance.

In the left graph, the output response for each section (lowered 20dB) is shown. Blue-Woofers, Green- Midrange, and Red-Tweeter. The Black curve is the total system response with all sections in-phase, and the Purple curve shows the system response with the Midrange summed out-of-phase. The right graph shows the magnitude and phase of the total system impedance.

## General Specifications & Capabilities

### ■ Target System / General

16 Transfer Function Blocks (TFBs) any math combination.  
20 TFB Filter Types: LP1, LP2, HP1, HP2, AP1, AP2, BP1, BR1, LP½, HP½, LEQ, HEQ, BEQ, RAT1, RAT2, AAP1, AAP2, SINC, IIR, FIR.  
32 Order (Poles/Zeros) for S-Plane Analog Functions.  
32 Section up to 64 Order IIR per TFB.  
IIR realization for Single, Parallel, Cascade sections.  
8192 Order FIR per TFB.  
S & Z Plane Polynomial Editing and Root Analysis.  
IIR Single, Parallel, Cascade Transformations.  
FIR Half-Delay and Interpolation Transformations.  
IIR/FIR Coefficient data Import/Export.  
Analog Target Optimizer, via curve or constraints.  
8 Storage Memory groups for Target Parameter sets.

### ■ Target System / Analog Filters

1-16 Order Filters (32 poles/zeros).  
5 Transformations: Lowpass, Highpass, Allpass, Bandpass, Bandreject.  
13 Allpole Families: Butterworth-3dB, Butterworth-6dB, Chebyshev, Bessel, Legendre, Linear Phase, Transitional-3dB, Transitional-6dB, Transitional-12dB, Synchronous, Gaussian, MCP Butterworth, MCP Chebyshev. (MCP : Multiple Critical Pole)  
Linear Phase with any Group Delay ripple.  
Chebyshev with any passband ripple.  
4 Elliptic Families: Maximal-Flat, Equal-Ripple, MCP Maximal-Flat, MCP Equal-Ripple.  
Even order Elliptics with Finite or Infinite zero.  
Elliptics can have any passband/stopband ripple.  
Transition threshold user definable for all filters.  
Inverse IIR Transform.  
Rational polynomial approximation.  
S-Plane Root Editor.

### ■ Target System / Digital IIR Filters

6 Transformation Methods: Matched-Z, Bilinear, Impulse-Invariant, Sine-Invariant, Step-Invariant, Convolution.  
3 Realization Forms: Single, Parallel, Cascade.  
Recursive Running Sum Filters.  
Frequency Domain Approximation.  
Time Domain Approximation.  
Z-Plane Root Editor.

### ■ Target System / Digital FIR Filters

4 Types of Optimal Filters: Linear Phase Bipolar, Linear Phase Unipolar, Minimum Phase, Maximum Phase.  
4 Transformations: Lowpass, Highpass, Bandpass, Bandreject.  
Optimal Filters with custom response for passband/stopband.  
Optimal Halfband and Multiband Filters.  
Optimal Interpolated and Multirate Filters, optimized design.  
Optimal Hilbert Transformer and 1st, 2nd, 3rd differentiators.  
Optimal single band approximation.  
Comb and Maximally Flat Filters.  
30 Window Function Families.  
Frequency Sampling Filters.  
Z-Plane Root Editor.

### ■ Circuit Components

21 Components specialized for filter design featuring:  
RLC components, standard values for 1%, 5%, 10%, 20%.  
Inductors with parasitic losses.  
Frequency Dependent Negative Resistors (FDNR).  
Potentiometers with taps and definable tapers.  
Switches with 1-26 number of positions with parasitic losses.  
Impedance component defined by imported Z curve.  
Generator with custom transfer function.  
Opamp with fast AC-model including noise.  
Buffer for precision gain and delay.  
Transfer Function component, general purpose ungrounded.  
Switched Capacitor Network (SCN).  
Summer for precision add/sub operations, 2 or 3 inputs.  
Digital IIR filter component.  
Digital FIR-filter component.

### ■ Circuit Editing and Analysis

2000 Component limit.  
A, B, C, D, E size drawing pages.  
Schematic entry and editing.  
Specialized AC Circuit Simulator with InvFFT.  
Impedance Scaling of entire circuit.  
Analog Circuit Optimizer, with curve or constraints, scalar magnitude, vector magnitude, or group delay.

### ■ Circuit Synthesis

500 predefined circuits with built in direct design support.  
Numerous variety of active filters from 1-16 order.  
Gyrator circuits with equivalent L/D design.  
Extensive inventory of RLC ladders from 1-16 order, including single term and double term Min-L & Min-C.  
RDC Ladders 1-16 order.  
Equalizer circuits with potentiometer components.  
Switched Capacitor state variable circuits.  
Digital IIR parallel and cascade multistage circuits.  
Digital FIR multistage circuits.

### ■ Processing

Noise Analysis, total noise across any bandwidth, with ANSI weighting filters A, B, C or flat.  
Sensitivity Analysis, each component, worst case frequency.  
Monte Carlo Analysis, with selectable component types.  
Thermal Analysis, from Tmin to Tmax in up to 32 steps.  
Potentiometer Analysis, auto pot rotation in up to 32 steps.  
Minimum Phase Transform, generate phase from magnitude.  
Delay Phase Transform, generate phase from delay.  
Binary Math operations, Add/Sub/Mul/Div curves.  
Unary Math operations, scale, smooth, exp curves.

### ■ Utilities

Import/Export frequency or time domain curve data.  
Export of Vector and Raster graphical images.  
Clipboard transfer of graphics or text data.  
Curve Editor, draw or edit curves manually.  
Curve Capture, distill curve from raster image data.  
Library system for Opamp Models.  
Library system for Potentiometer Taper Models.

### Minimum System Requirements

- Mouse and Keyboard
- LPT port or USB port
- Windows® 95, 98, NT4, 2000
- 125MB free Hard Drive space
- 32MB RAM Memory
- Pentium® 166 or equivalent
- Video 800 x 600 Resolution / 256 Colors
- TrueType® or Adobe® Fonts

### Recommended System Requirements

- Windows® NT4 or Windows® 2000
- 200MB free Hard Drive space
- 64MB RAM Memory or more
- Pentium-II® / 350 or equivalent
- Video 1024 x 768 Res / 64K or 16M Colors
- Adobe® Fonts with Adobe Type Manager®



Contact factory for international dealers



All specifications subject to change without notice.  
© 1999 All Rights Reserved.  
Printed in the U.S.A.  
07.01.1999

**LINEARX SYSTEMS INC**  
9500 SW Tualatin-Sherwood Rd  
Tualatin, OR -97062-8586 USA  
Tel: 503-612-9565 Fax: 503-612-9344  
www.linearx.com sales@linearx.com