

Features & Capabilities

- 20W/4 - 10W/8 Output Power
- Very Wide Bandwidth DC - 200kHz
- Very Low Output Distortion
- Very Low Output Impedance
- BNC Voltage Monitor Output
- BNC Current Monitor Output
- True Voltage Source Impedance
- Simultaneous SPL & Impedance
- Balanced/Unbalanced XLR Input
- Selectable Gain: 0dB,+10dB,+20dB
- Floating Isolated Common
- High Frequency Output Stage
- Auto Bias Output Stage
- Dynamic Bias Output Stage
- Temperature Overload Protection
- Short Circuit Current Protection

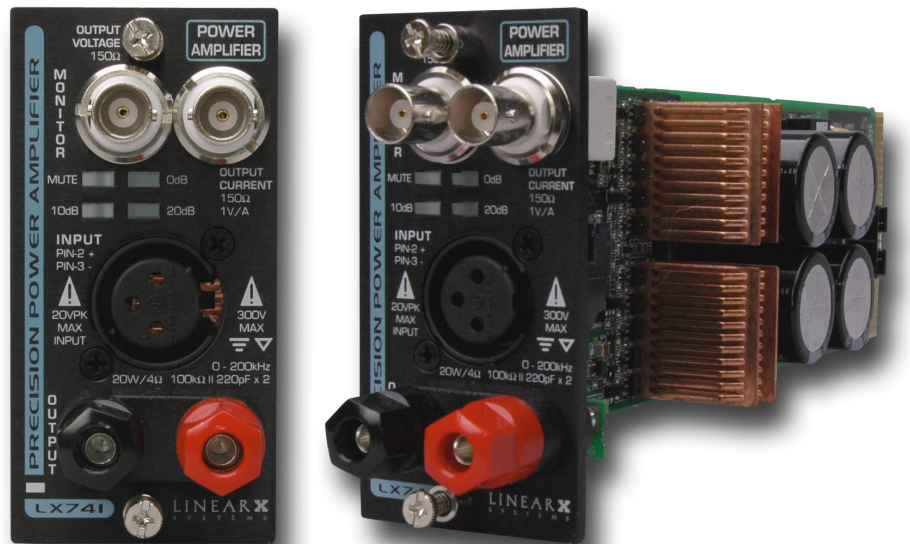

LX741 - 20 Watt Power Amplifier

Conventional power amplifiers serving audio signal requirements are typically concerned with 20kHz bandwidth. However, since the LX711 and LX721 signal processing modules cover the much wider bandwidth of 200kHz, the need for a wide band power amplifier suitable for reference measurements is desirable.

Many loudspeaker measurements also involve very low frequencies, and for this reason a power amplifier with response down to DC is also ideal. This enables ultra low frequency measurements to be performed with zero phase shift.

High quality true impedance measurements require that a loudspeaker be driven under voltage source conditions, rather than current source conditions. The LX741 provides both voltage and current monitor outputs which enable true impedance to be obtained by merely dividing the signal data. Acoustic SPL data can also be measured at the same time.

High Performance Power Stage

Typical audio power amplifiers employ power output transistors which have gain bandwidth products of 20-60MHz. While this generally meets the needs of amplifiers handling frequencies to 20kHz, a 200kHz amplifier places an order of magnitude higher demands on the output stage. The LX741 features an output stage created from a large array of small signal transistors, with gain bandwidth products of 650MHz. This enables very low stored charge in the LX741 output stage to handle 200kHz signals as easily as conventional amplifiers handle 20kHz signals.

To reduce high frequency distortion further, the LX741 output stage also features auto bias and dynamic bias circuitry. Conventional amplifiers generally operate in a manner where current through one side of the output stage is entirely shut off during high current in the other side. This produces a substantial discontinuity that becomes difficult to correct at higher frequencies where less loop gain is available. The LX741 maintains bias current in both halves of the output stage during all signal transitions providing a much more linear power voltage follower. The output stage also features custom SMT heatsink convection cooling, current limiting, and temperature sensing for enhanced overload protection. Amplifier current is not returned to the LX700 common.

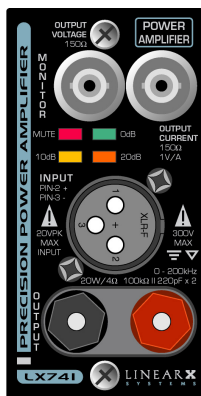
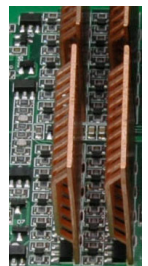

LX741 - Panel Features

The main output connectors of the LX741 are 5-Way (BLK/RED) binding posts for standard connection to the loudspeaker or other load device. The XLR female input connector provides for typical connection to balanced or unbalanced signal sources. For most applications this will be the typical configuration, eliminating both ground loops and common mode noise between any source and the LX741 power amplifier. However, if true unbalanced connection is desired, two internal jumpers are also provided to force the amplifier common to chassis ground, and to connect Pin-3 to the COM/GND as well.

Two BNC connectors are provided for the Voltage and Current monitor outputs. Each of these outputs provide the means to obtain both voltage and current signal data associated with the load. Since the load is driven under true voltage source drive conditions, acoustic SPL data on the driver can also be obtained at the same time.

This enables true and accurate impedance data to be obtained as driven by a low impedance voltage source. This also allows distortion in the current signal of the load to be easily measured, or acoustic distortion at the same time. Four color coded LED indicators are provided to indicate signal condition and gain. They are: MUTE, 0.0dB, +10.0dB, and +20.0dB. These indicators reflect software program control settings and/or configuration changes.

Specifications

| | |
|--------------------------------|--|
| • Power Output | 20 Watts RMS / 4 Ohm, 10 Watts RMS/ 8 Ohm |
| • Maximum Voltage Output | 9.5 VRMS |
| • Maximum Current Output | 2.5 ARMS |
| • Bandwidth | $\pm 0.005\text{dB DC-20kHz}$, $\pm 0.3\text{dB DC-200kHz}$ |
| • Distortion (1kHz) | <0.01% |
| • Slew Rate | 20V/uSec |
| • Common Mode Rejection (1kHz) | 100dB |
| • Gain | 0.00dB, +10.00dB, +20.00dB |
| • Gain Accuracy | 0.01dB |
| • Input Impedance | 100k Ohms |
| • Input Connector | XLR Female, Balanced, Unbalanced |
| • Output Connector | 5-Way Binding Posts, 0.75 Inch Pitch |
| • Output Offset Voltage | $\pm 10\text{mVDC}$ |
| • Current Limit | 5 Amps, 1 sec timer retry |
| • Temperature Overload | Yes |
| • Monitor Output Connector | BNC |
| • Monitor Output Impedance | 150 Ohms |
| • Monitor Voltage Scale Factor | 1V/V |
| • Monitor Current Scale Factor | 1V/A |
| • Monitor Voltage Accuracy | Calibrated to 0.1% |
| • Monitor Current Accuracy | Calibrated to 0.1% |
| • Power Amplifier Grounding | Isolated Floating Common |
| • DC/DC Converter Frequency | 300kHz |
| • Module Bus Interface | LXBUS, 50 pin Card Edge Connector |
| • Module Face Plate | 0.125 Black Anodized Aluminum |
| • Module Height | 3.50 Inches |
| • Module Width | 1.75 Inches |
| • Module Length | 9.50 Inches |
| • Module Weight | 0.5 lbs (0.22kg) |

LINEAR X
S Y S T E M S
Computer Aided Engineering & Measurement Systems

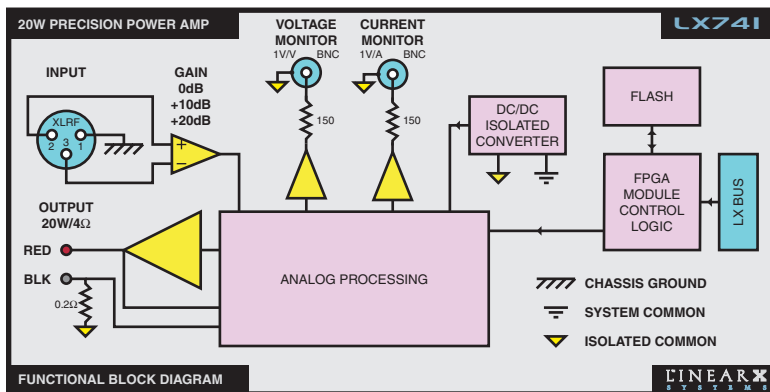

Automated Digital Calibration

The LX741 does not contain any analog trim pots. Instead all calibrations and trimming are performed by automated computer controlled routines in a GPIB test system, with adjustments provided by digital trim DACs or digital constants. All calibrations are stored within the non-volatile flash memory of each module, and performed with traceable equipment and standards. Accuracy is measured to better than 0.01dB or 0.1%, as applicable to each parameter. A calibration chart is included with each module to document the actual performance, parameters, and calibration results.



Visit our web site or contact the factory for a list of International Dealers.



LINEARX SYSTEMS INC

9500 SW Tualatin-Sherwood Rd
Tualatin, OR 97062-8586 USA
Tel: 503-612-9565 Fax: 503-612-9344
www.linearx.com sales@linearx.com

All specifications subject to change without notice.
© 2009 All Rights Reserved.
Printed in the U.S.A.
JUL-01-2009